

**EFFECTS OF ENVIRONMENTAL EXPOSURE
ON TIMBER RAILROAD BRIDGE/TRACK
MEMBERS AND CONNECTORS**

Travis Burgers
Jeno Balogh, Ph.D
Richard Gutkowski, Ph.D., P.E.

December 2004

ACKNOWLEDGEMENTS

This report has been prepared with funds provided by the United States Department of Transportation to the Mountain-Plains Consortium (MPC). The authors acknowledge the support of the Structural Engineering Laboratory and the Composite Materials, Manufacture and Structures Laboratory at Colorado State University for the use of test and measurement equipment critical to the collection and evaluation of the data in this report. The researchers thank the following individuals for their help in this project: fellow graduate students Cem Ayan, Steve Babcock, and Misty Butler, Elliot DeJongh; lab assistant Kathryn Sednek; and summer undergraduate researchers Charles Manu and Antonio Marques. Financial support was provided for the latter two students from the McNair Peaks Summer Research Internship Program and the CIT bridge program, respectively.

DISCLAIMER

The contents of this paper reflect the views of the authors who are responsible for the facts and the accuracy of the information presented. This document is disseminated under the sponsorship of the Department of Transportation, University Transportation Centers Program, in the interest of information exchange. The United States Government assumes no liability for the contents or use thereof.

ABSTRACT

A pilot experimental study examined the time-dependent mechanical effects of moisture, temperature and humidity on a particular connection detail of open-deck timber trestle railroad bridge chord. A full-scale specimen was conceived to include the standard inter-connections of the steel rail to wood cross-tie to multi-ply chord member. The full-scale section of a timber trestle railroad bridge was tested to observe the time-dependent mechanical effects of temperature and humidity on timber trestle railroad bridge connections by analyzing the load-sharing effects of the plies through the transverse connector rods. The three-ply test specimen was built using full-scale members. The specimen spanned 67 inches and was composed of seven wood crossties. It was ramp tested on each of its three plies and vertical displacement measurements were taken. The test specimen was then subjected to changes in temperature and humidity in an environmental chamber and then it was ramp tested again. The results of the test were unexpected as the midspan deflection of the east ply increased 82 percent while its load increased 1.1 percent; the midspan deflection of the west ply increased by 7 percent while its load decreased 0.8 percent. Despite the changes in deflection, the load sharing through the plies remained nearly unchanged.

TABLE OF CONTENTS

1. INTRODUCTION.....	1
1.1 Introduction.....	1
2. LITERATURE REVIEW	3
3. STANDARD BRIDGE GEOMETRY.....	5
4. EXPERIMENTAL TESTS	7
4.1 Test Specimen Geometry.....	7
4.2 Load Test Setup and Procedure	9
4.3 Results	11
5. LOAD SHARE ANALYSIS	15
6. OBSERVATIONS.....	19
7. CONCLUSION AND RECOMMENDATIONS	21
8. REFERENCES	23
9. APPENDIX.....	25
9.1 Appendix A.....	25
9.2 Appendix B.....	26
9.3 Appendix C	27

LIST OF FIGURES

Figure 1. Schematic of a standard open-deck timber trestle railroad bridge	1
Figure 2. Standard open-deck timber trestle railroad bridge	2
Figure 3. Dimensions of the test specimen.....	7
Figure 4. Side view of the (upside down) specimen load test setup.....	8
Figure 5. End supports for the test specimen.....	9
Figure 6. String potentiometer locations	10
Figure 7. Midspan deflections due to loading on center ply (Test 1)	11
Figure 8. Midspan deflections due to loading on west ply (Test 1).....	12
Figure 9. Midspan deflections due to loading on east ply (Test 1).....	12
Figure 10. Midspan deflections due to loading on center ply (Test 2)	13
Figure 11. Midspan deflections due to loading on west ply (Test 2).....	13
Figure 12. Midspan deflections due to loading on east ply (Test 2).....	14
Figure 13. 20 kip load distribution (Test 1).....	16
Figure 14. 20 kip load distribution (Test 2).....	16
Figure 15. 25 kip load distribution (Test 1).....	16
Figure 16. 25 kip load distribution (Test 2).....	16
Figure 17. 27 kip load distribution (Test 1).....	17
Figure 18. 27 kip load distribution (Test 2).....	17
Figure 19. Average load distribution (Test 1).....	17
Figure 20. Average load distribution (Test 2).....	17

EXECUTIVE SUMMARY

The structural condition of short span railroad bridges can be characterized as one of increasing nationwide concern. Many have been in service for 50 to 100 years, particularly on short lines in sparsely populated areas. During service life, single car loads have increased enormously and the frequency of dual cars has risen dramatically. One type of bridge commonly used is the open-deck timber trestle bridge. Reports by the Canadian National Railway and the Association of American Railroads (AAR) indicate that degradation has been occurring along with material failure evident at some sites. Existing bridges are being considered for upgrading to safely carry these increased loads to avoid potential structural problems leading to costly replacements.

The AAR is involved a strategic research program to investigate the structural performance of existing and strengthened timber bridges via a program of field load tests. A national plan to upgrade then can be formulated. One goal is to avoid unnecessary costly replacements or major repairs. For example, prior joint MPC-AAR supported projects examined the load response of existing and strengthened open-deck timber bridges using field and laboratory load tests.

This report describes the results of examining the effects of weather exposure conditions on the connection details of the open-deck timber trestle bridge. As an exploratory experimental study, the time-dependent mechanical effects of moisture, temperature and humidity on a particular connection detail was observed. A full-scale specimen, including the standard interconnections of the steel rail to wood cross-tie to multi-ply chord member, was constructed. The specimen was then exposed to extremes of temperature and humidity on an accelerated time basis over 2 to 3 months. An environmental chamber was used to create the desired exposure conditions. At selected times, the conditioned specimen was removed and subjected to a flexural load test. The change in deflection and load sharing was observed via physical measurements. Although the deflection changed measurably, the load sharing between the plies of the chord remained essentially the same.

The outcome of the study is a step toward examining the outcome of upgrades made to bridges comprised of old timbers and the subsequent effects of the environmental climate changes on them. This particularly relates to fastening of new steel or wood components into aged pieces of wood. It is planned to follow this pilot study with more comprehensive studies of a broad range of specimen configurations and environmental conditions as well as significantly longer exposure time periods.

This research promotes the maintenance of effective, efficient railroad services to small communities. Concern for viability of the railroad bridges is high as safety issues add to the concerns of a recent history of short line closures. The impact of railroad bridge failures or closures on intermodal freight movement can be devastating to local, state and regional agricultural and freight economies. The results of this research are pertinent to maintain or upgrade railroad bridges on main lines and short lines vital to the effective transport of agricultural goods and freight throughout the region and country.

1. INTRODUCTION

1.1 Introduction

A laboratory specimen was built from full-scale members to simulate the main components of an open-deck, timber trestle railroad bridge. The specimen was experimentally tested to observe the time-dependent mechanical effects of temperature and humidity on timber trestle railroad bridge connections by analyzing the load-sharing effects of the plies through the transverse connector rods. This was accomplished by exposing the specimen to changes in temperature and humidity in an environmental chamber. It was hypothesized that each member of the specimen has similar material properties and will be affected in a similar manner because of their exposure in an environmental chamber. It is also hypothesized that the rods would loosen slightly because of the exposure conditions.

The analysis of timber trestle railroad bridges commonly used in the United States is part of ongoing research being conducted at Colorado State University (CSU). Figure 1 shows a schematic of a standard open-deck timber trestle railroad bridge which is the basis of the laboratory specimen. An example of this type of bridge is shown in Figure 2. It crosses the Cache la Poudre River in Fort Collins, Colo., southwest of the intersection of College Avenue (US Highway 287) and Vine Drive.

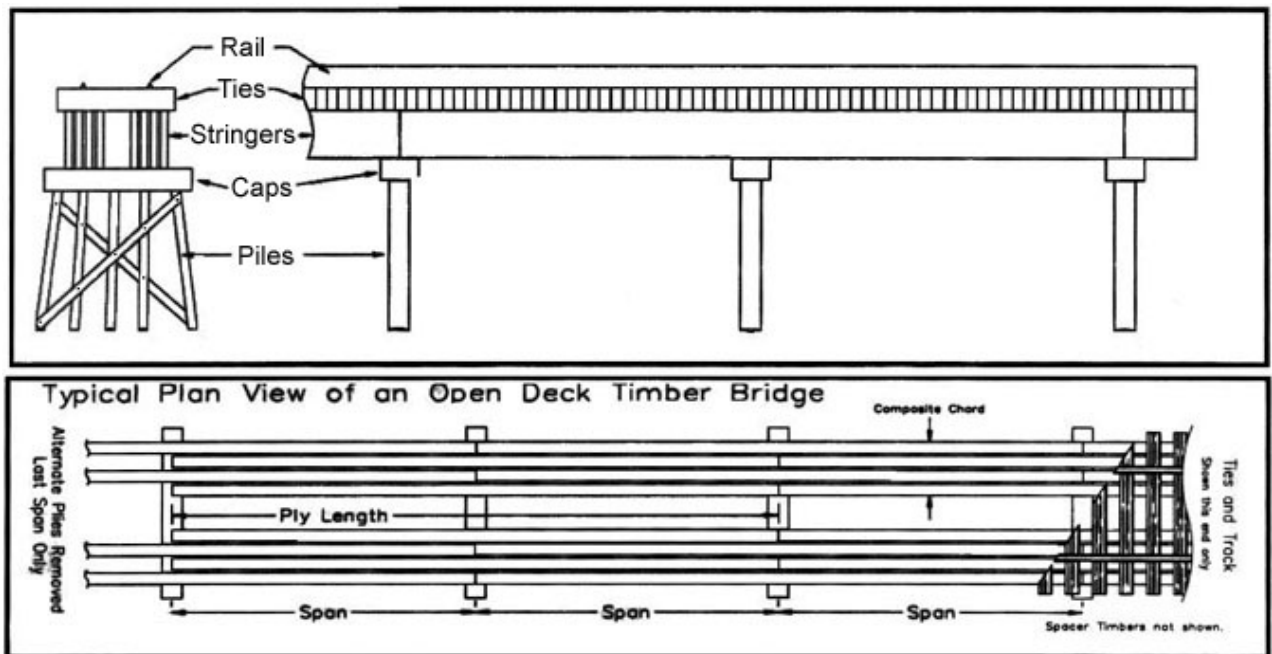

Figure 1. Schematic of a standard open-deck timber trestle railroad bridge



Figure 2. Standard open-deck timber trestle railroad bridge

2. LITERATURE REVIEW

There has been much research on timber trestle railroad bridges in the field and in the laboratory. A brief description of selected references follow.

In 1981, Siegel and Cerny³ retrofitted a number of bridges on the Columbus and Greenville Railway by adding a third stringer to a two-stringer chord. After the retrofit, the bridges were load tested and the load shared between the three stringers was measured. The testing was a success despite the fact that the addition of the third stringer caused the chord to be off-center from the rail. The average distribution was 26 percent to the new outside stringer, 32 percent to the center and 42 percent to the inside stringer.

The Association of American Railroads (AAR) has done considerable research on timber trestle bridges. With funding from the AAR, Wipf et al.⁷ researched two bridges on Southern Pacific's southwest Texas line to determine the vertical load distribution. The two bridges were in relatively poor condition and they were scheduled for rehabilitation. Wipf et al. found that the four stringers in a chord did not act as a composite unit because there was unequal load distribution to the stringers and the unequal load distribution was more pronounced when replacement stringers had been used with the relatively poor existing stringers. This was credited to the uneven bearing between the ties and the stringers and the poor quality of the timber members. The stringers in a chord were also observed to experience non-uniform deflections.

The AAR has also supported a number of laboratory projects. At the University of Illinois at Urbana-Champaign, Chow et al.¹ performed testing to determine the ultimate static bending moment of 100 8" x 16" bridge stringers. Uppal⁴ notes that at Texas A&M, static and dynamic fatigue testing was performed on Douglas fir, southern pine and southern pine glue-laminated stringers to determine their fatigue s-n curves.

Colorado State University (CSU) has been involved in a number of similar research projects. Field testing was done on three bridges in Colorado as a cooperative effort by CSU and the AAR⁵. Static and rolling tests were performed. No consistent deflection pattern for interior versus exterior stringers was observed. The deflection of the two chords in a span also differed. In a four stringer chord the load sharing was found to vary between 17 percent and 35 percent for an individual stringer, meaning at times one stringer can carry twice as much as another stringer in the same chord.

CSU and the AAR⁶ later did research on the addition of helper stringers to the three bridges that were field tested earlier. The additional stringer was added outside each chord and load testing was performed. The load sharing with the addition of the helper stringer showed that the maximum load an individual stringer carried was 29 percent however, there seemed to be no pattern of the sharing between internal and external stringers.

As a continuation of the helper stringer research, Gutkowski et al.² added helper stringers to a full-scale timber trestle bridge specimen. This specimen replicated the major components of a three-span bridge. It was tested and then disassembled. It was reassembled into a two-span specimen, tested and disassembled. This was repeated for a one-span specimen.

3. STANDARD BRIDGE GEOMETRY

The major components of the bridge in Figure 2 consist of creosote-treated, Douglas fir solid sawn timbers. This 31-span bridge has two chords consisting of four spaced plies. Each span is 15' long. In both chords, 30' plies are continuous over two spans, but their ends are staggered one span. In the end span, alternate plies are 15' supported members.

The bridge substructure is comprised of timber pile abutments and intermediate pile bents. Each support includes five 12" diameter piles. Two 4" x 8" beams are used as diagonal cross bracing on the piles. A timber cap is atop each set of piles. The dimensions of the cap are 13.5" x 11" x 9'.

The cap supports two chords. Both chords consist of four plies; the cross-sectional dimensions of the plies are 8" x 15.5". Four 2" spacers separate the plies in each chord at each cap. Four $\frac{5}{8}$ " diameter transverse steel connector rods are oriented in a rectangular configuration. Each rod runs through the spacers and connects all the plies in the chord. These connector rods are spaced 13.5" longitudinally so that they are aligned with each edge of the cap.

Wood crossties are located directly above the chords. The dimensions of the each crosstie are 7.5" x 7.5" x 8.5' and they are oriented perpendicular to the tracks. The wood crossties are spaced an average of 4" apart. Two timber guardrails run parallel with the tracks atop the wood crossties. The dimensions of these guardrails are 7.5" x 4.5". They run outside the railroad tracks, approximately 6" from the edge of each crosstie. A $\frac{3}{4}$ " connector rod runs vertically through the cap, plies, wood crossties and guard rails on every fourth wood crosstie. The two steel railroad tracks are attached to the wood crossties.

The $\frac{3}{4}$ " diameter transverse tie rods that connect the three plies are spaced in a rectangular configuration similar to the tie rod spacing in the example railroad bridge. The holes are lined up with the outside of the cap just as they are in the example railroad bridge, approximately 13.5" on center on the specimen. The tie rod holes are also spaced 8" vertically.

The cross-sectional dimensions of the guardrail are $3\frac{3}{8}$ " x $3\frac{3}{8}$ " and it spans the same distance as the plies, 6' 1". Because the specimen is not as wide as the actual bridge because of the width restriction of the environmental chamber door, one timber guardrail was chosen to run in between the tracks. The steel railroad tracks were placed directly under the outer two plies for stability when loading each ply individually.

A $\frac{3}{4}$ " diameter steel connector rod runs vertically through the center of the test specimen. The rod interconnects the single guardrail, center wood crosstie, center ply and cap. A $\frac{5}{8}$ " diameter steel connector rod vertically attaches the guardrail, the end crosstie and the center ply at each end of the specimen. The other four crossties are connected to the guardrail by $\frac{5}{8}$ " diameter lag bolts that are 6" in length.

Two standard steel rail segments are attached to the top of the seven crossties. Each rail is attached to the specimen by two $\frac{5}{8}$ " railroad spikes driven into the outer crosstie at each end of the test specimen. A $\frac{3}{8}$ " pilot hole was first drilled to prevent splitting in the crossties. The rails are only attached to the outer crosstie on each end because the rails would make the specimen too stiff to notice significant deflections under the applied load if they were completely attached. Since the rails are not attached to all the crossties, there is a gap between the inner five crossties and the rails so that the wood portion of the bridge can deflect unhindered by the rails.

The laboratory test specimen was built using primarily timber members that were already available at CSU. Consequently, the dimensions of the cap, plies, crossties, and guardrail slightly differ from those of the actual bridge. These members had been located outdoors exposed to the weather before their use in the railroad bridge test specimen.

Figure 4 shows the test setup of the specimen.



Figure 4. Side view of the (upside down) specimen load test setup

After construction, the cap was removed from the specimen so that a load could be applied to each individual ply rather than the three plies simultaneously through the cap.

4.2 Load Test Setup and Procedure

The test specimen was load tested after its construction. It was placed upside down (rails down) on two roller supports placed 3" from the edge of the rails. A photo of one of these roller supports can be seen in Figure 5.



Figure 5. End supports for the test specimen

The end supports were spaced 67" apart to simulate the longitudinal distance between the two front or rear axles of a railroad car. This dimension is approximate because there are many types of railroad cars with differing axle spacings. This is also the approximate distance between the zero moment (inflection) points on either side of the cap. The load was applied through the underside of the bridge so that the two point loads from the train axles would be uniform and the test specimen would be more stable in the frame during loading than if the specimen were right-side up and two loads of the same magnitude were applied simultaneously.

A ramp load was applied at a rate of 0.002 in./sec to simulate a static load during the testing. Load tests were done on each of the three plies. Deflection measurements were taken at four locations by string potentiometers. The location of the string potentiometers and the three loading positions (P) are shown in Figure 6. String potentiometers were attached at the following locations on the test specimen: immediately above the west end of the north-most crosstie, immediately above the west end of the south-most crosstie, and immediately above the center crosstie on each of the east and west sides.

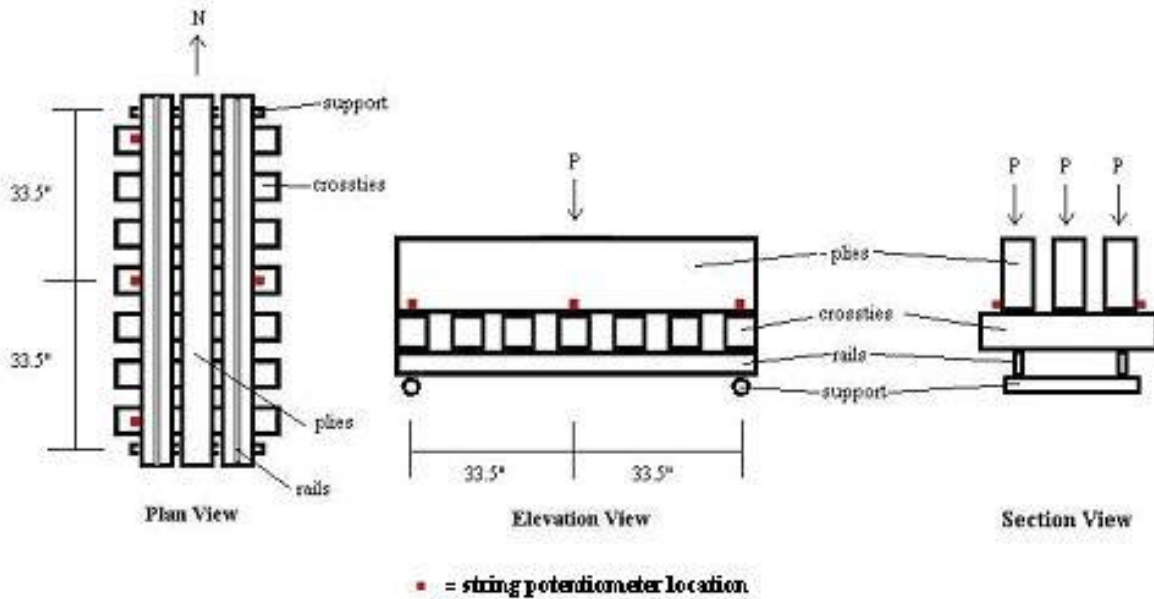

Figure 6. String potentiometer locations

Exposure periods and load tests were as follows:

1. 20 days of exposure in the environmental chamber
2. Initial ramp load tests on the individual plies
3. 41 additional days of exposure in the environmental chamber
4. Second set of ramp load tests on the individual plies

The environmental chamber was set to 100 F and 90 percent relative humidity during the day and at night the door was opened so that the chamber could cool and dehumidify. The test specimen was exposed to these conditions to simulate the exposure conditions of a bridge in the field. The bridge was subject to these conditions for 55.5 hours over 20 days before it tested. The exposure time, minimum overnight temperature and minimum overnight humidity are recorded in Appendix A.

After the initial exposure period, ramp load tests were performed on each of the three plies individually and deflection measurements were taken at the four locations. The specimen was returned to the environmental chamber and was again exposed to 100 F and 90 percent relative humidity conditions for an additional 134 hours over a time period of 41 days. The exposure time, minimum overnight temperature and minimum overnight humidity are recorded in Appendix B. After this time in the environmental chamber, the specimen was tested in the same way on each of the three plies for a second time.

4.3 Results

The measured load versus deflection plots for the midspan of the plies are shown in Figures 7 through 12. A negative deflection is vertically downward. Test 1 in these figures corresponds to the initial test after the initial exposure period (55.5 hours over 20 days) and Test 2 corresponds to the test after the specimen was exposed in the environmental chamber the second time (for 134 hours over 41 days).

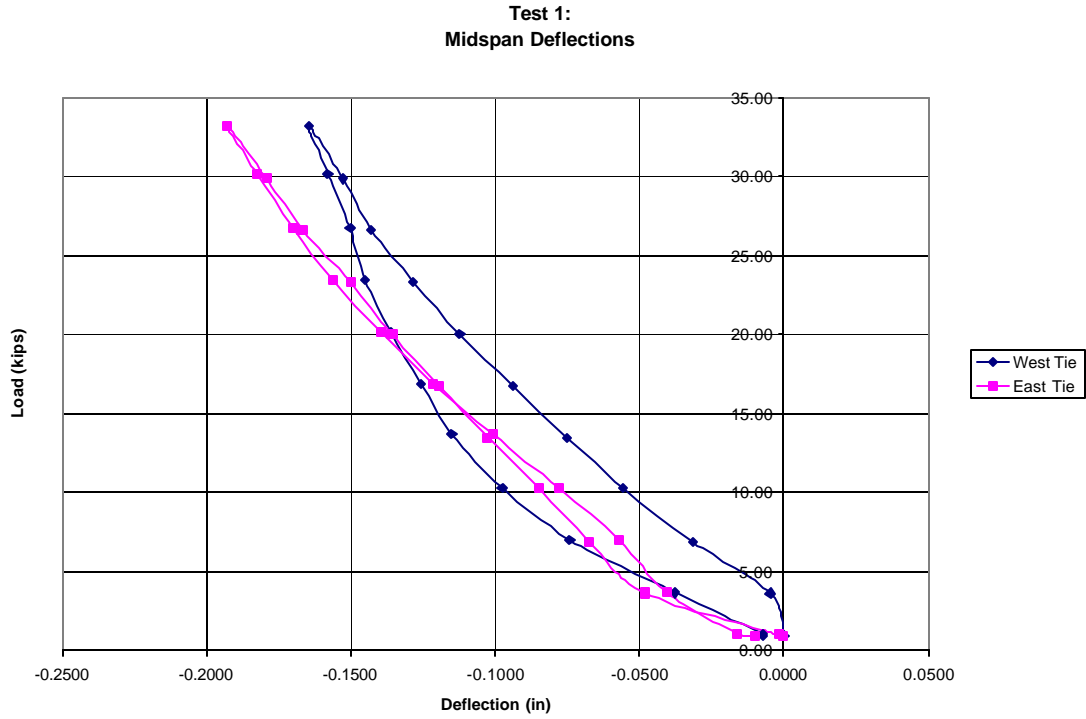

Figure 7. Midspan deflections due to loading on center ply (Test 1)

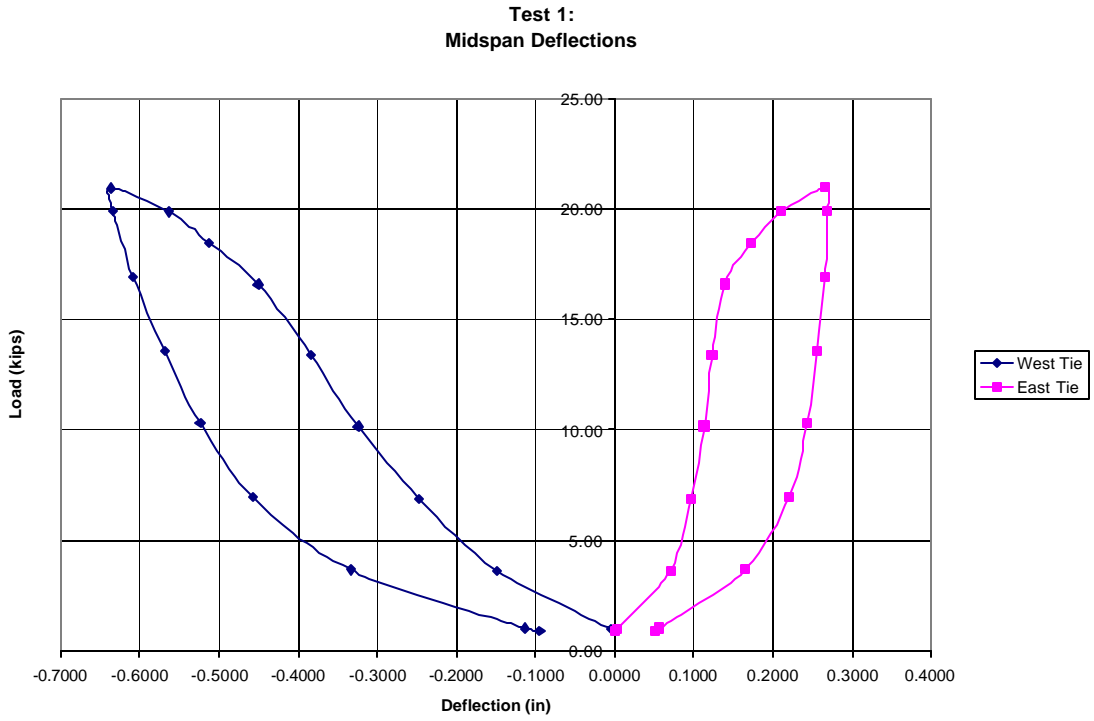

Figure 8. Midspan deflections due to loading on west ply (Test 1)

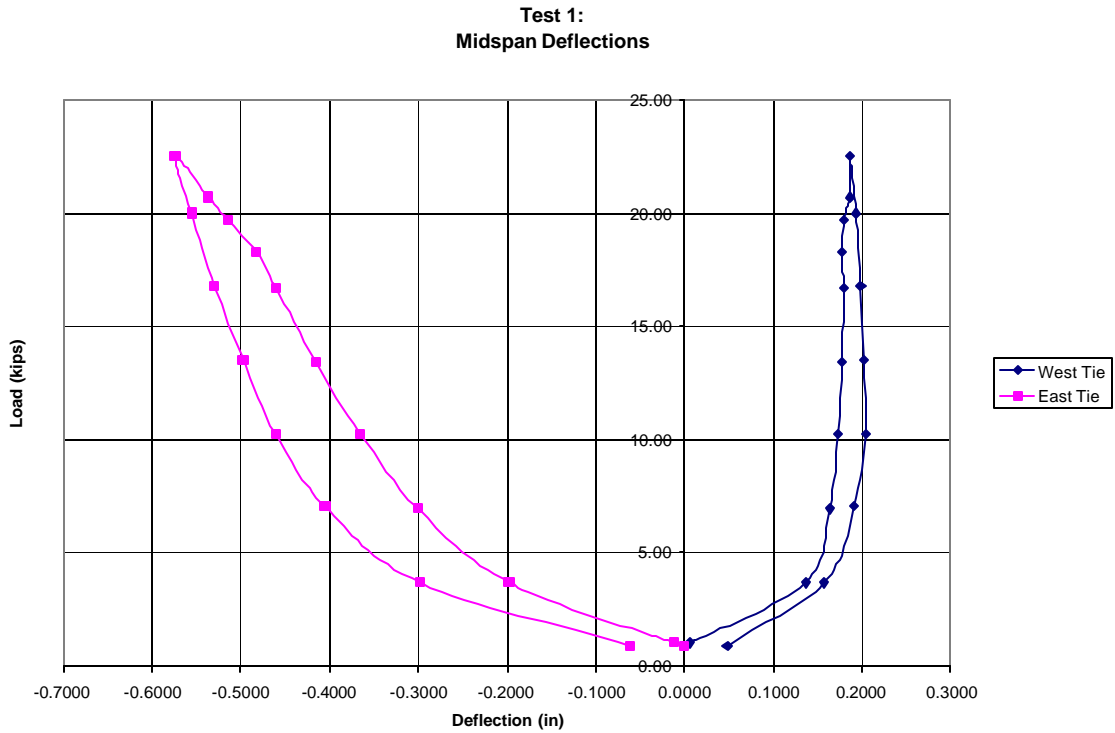

Figure 9. Midspan deflections due to loading on east ply (Test 1)

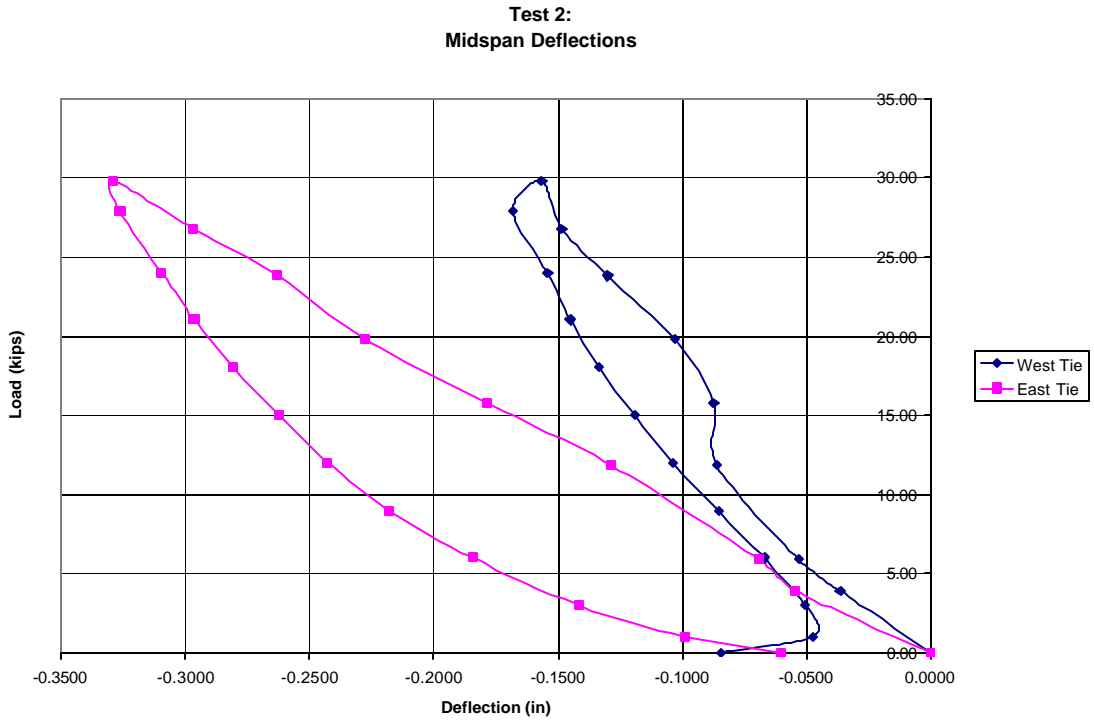

Figure 10. Midspan deflections due to loading on center ply (Test 2)

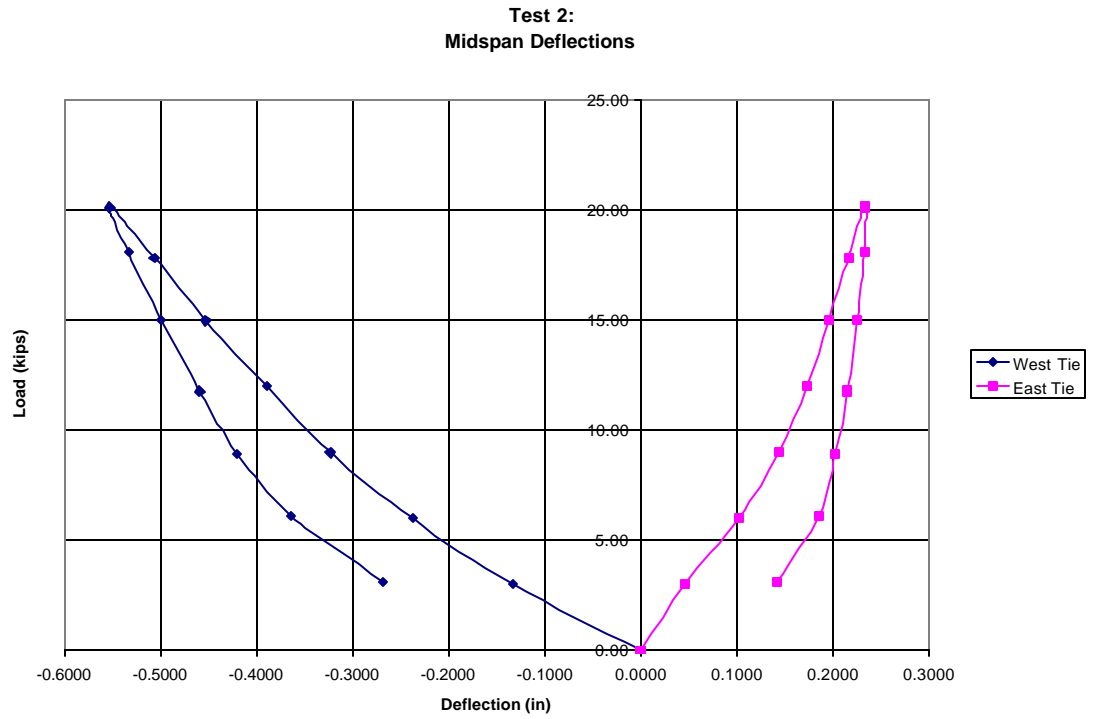

Figure 11. Midspan deflections due to loading on west ply (Test 2)

Test 2:
Midspan Deflections

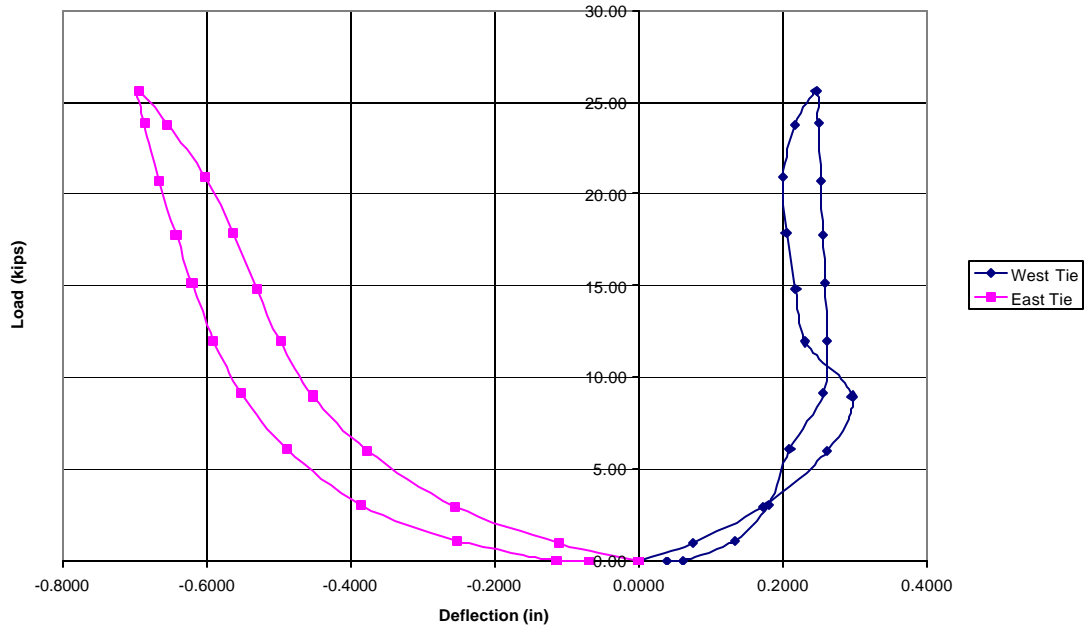

Figure 12. Midspan deflections due to loading on east ply (Test 2)

5. LOAD SHARE ANALYSIS

Three loading levels for the center ply were chosen to determine the load sharing through the transverse rods. These loads were 20, 25 and 27 kips. These three loads are 69, 86 and 93 percent of the maximum load applied during the testing. At each load, the vertical deflection at the midspan of each the west and east plies was found from the measured load versus deflection plot. A summary of these results is also shown in Appendix C.

For the first test, the measured load versus deflection graph shows that the 27 kip load on the center ply causes a vertical downward deflection of 0.1700 and 0.1475 inches in the east and west plies respectively (Figure 7). When the load is applied to the east ply, 2.7 kips are required to make it deflect downward 0.1700 inches, the same deflection that occurs when the 27 kip load is applied to the center ply (Figure 9). When the load is applied to the west ply, 2.5 kips are required to make it deflect downward 0.1475 inches, the same deflection that occurs when the 27 kip load is applied to the center ply (Figure 8).

The load necessary to cause the deflection under the east and west plies is considerably smaller when the load is applied to those respective plies as compared to the center ply. When the specimen is loaded over the center ply, 2.7 kips must be transferred to the east ply to make it deflect downward 0.1700 inches and 2.5 kips must be transferred to the west ply to make it deflect downward 0.1475 inches. This load transfer occurs through the transverse connector rods.

After it was determined that the east ply carries 2.7 kips and the west 2.5 kips, the load in the center ply is found. Clearly in this case, the center keeps 21.8 kips of the original 27 kip load. The percentages of the total load carried are also calculated. The east ply carries 10.0 percent, the west 9.3 percent, and the center 80.7 percent.

The deflections of the 25 kips center ply load are 0.1600 and 0.1425 inches downward for the east and west plies respectively. These deflections led to the east, west, and center plies carrying 2.5 (10.0% of the total), 2.4 (9.6%), and 20.1 (80.4%) kips respectively. For the 20 kip load on the center the deflections are 0.1375 and 0.1250 inches downward. This is 2.3 (11.5% of the total), 2.3 (11.5%) and 15.4 (77.0%) kips for the east, west and center plies respectively.

The same load share analysis was done after the specimen was exposed to the changing temperature and humidity in the environmental chamber. Figures 10 through 12 were used to find the displacements. The deflections of the east and west plies for the second test were 0.3100 and 0.1575 inches downward for 27 kips. At this load the east, west and center plies carried 3.0 (11.1% of the total), 2.3 (8.5%) and 21.7 (80.4%) kips respectively. At the 25 kip load the deflections were 0.2950 and 0.1500 inches for the east and west plies, corresponding to 2.7 (10.8% of the total), 2.1 (8.4%) and 20.2 (80.8%) kips to the east, west and center plies respectively. When the load was 20 kips, the deflection was 0.2675 and 0.1225 inches in the east and west plies. These deflections cause loads of 2.3 (11.5% of the total), 1.7 (8.5%) and 16.0 (80.0%) kips in the east, west and center plies.

The diagrams of the load sharing are shown in the following figures. The two 20 kip tests are shown in Figures 13 and 14; the two 25 kip tests in Figures 15 and 16; and the two 27 kips tests in Figures 17 and 18. In each pair, the second test occurred after 41 days of exposure in the environmental chamber. The average percentages of the load sharing in the first and second tests are shown in Figure 19 and 20 respectively. The calculations can be found in Appendix C.

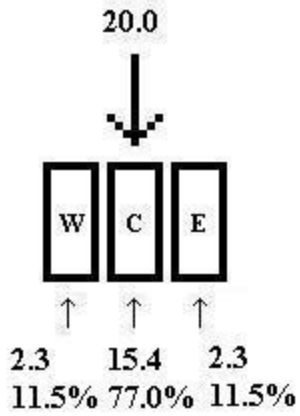

forces and reactions kips

Figure 13. 20 kip load distribution (Test 1)

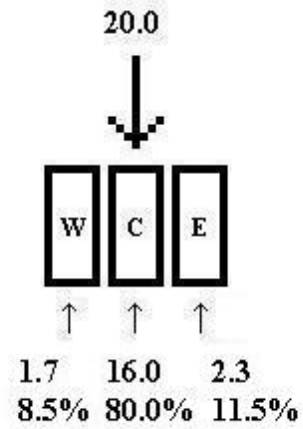

forces and reactions kips

Figure 14. 20 kip load distribution (Test 2)

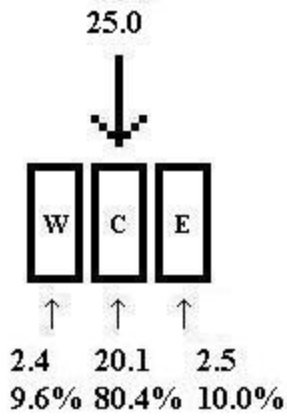

forces and reactions kips

Figure 15. 25 kip load distribution (Test 1)

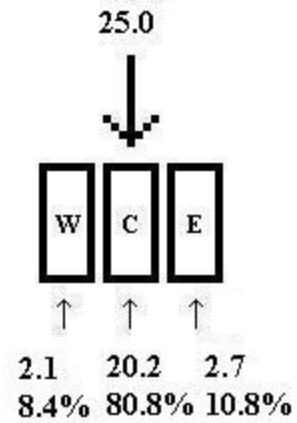

forces and reactions kips

Figure 16. 25 kip load distribution (Test 2)

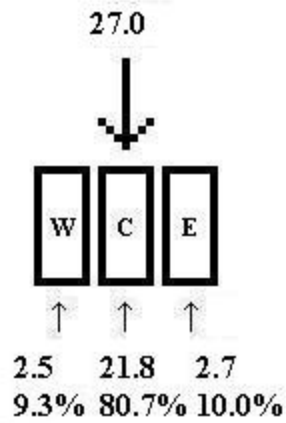

forces and reactions kips

Figure 17. 27 kip load distribution (Test 1)

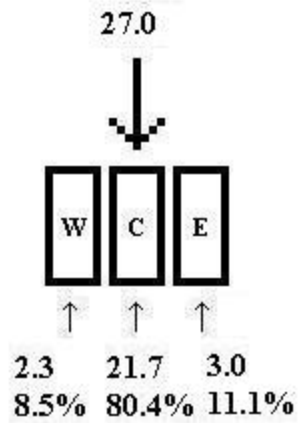

forces and reactions kips

Figure 18. 27 kip load distribution (Test 2)

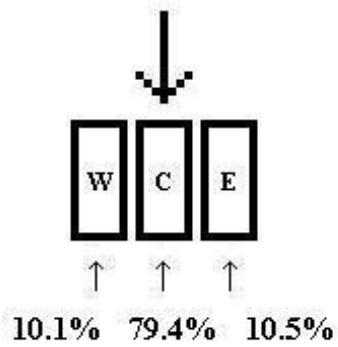

Figure 19. Average load distribution (Test 1)

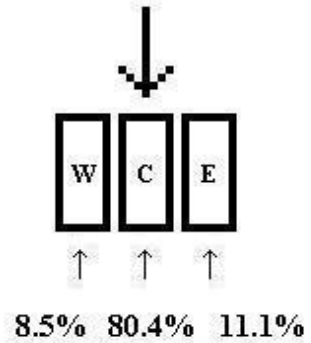

Figure 20. Average load distribution (Test 2)

6. OBSERVATIONS

In the load versus deflection graph of when the specimen was loaded on its east or west girder, the load versus deflection curve of the opposite ply is positive and very steep. This is because the opposite ply is physically deflecting upwards due to a rigid body rotation. Figure 9 is a good example of this. The east ply is being loaded and the west deflects upwards because of the rigid body rotation.

The vertical and transverse steel tie rods rusted soon after they were exposed to the changes in temperature and humidity in the environmental chamber.

From the comparison of the midspan deflections because of center ply loading in Figures 7 and 10, the test specimen showed significant degradation in the east ply but little in the west. In the first test, the east ply deflected 0.17 inches and the west ply 0.15 inches at a load of 27 kips. In the second test, the east deflected 0.31 inches and the west 0.16 inches under the same load. This corresponds to an 82 percent deflection increase in the east ply and a 7 percent increase in the west ply.

By comparing Figures 19 and 20, the average load distribution percentages, there was an increase in the load distributed to the east and center plies but a decrease in the load that went to the west ply. The load on the east and center plies increased from 10.5 percent to 11.1 percent and 79.4 percent to 80.4 percent respectively while the west ply decreased from 10.1 percent to 8.5 percent. This shows that the load sharing through the transverse connector rods remained nearly the same before and after the chamber exposure.

It makes sense that the deflections of the outer plies are very similar at 27 kips before the specimen was exposed to the chamber because the loads the west and east plies underwent were very close. The west ply received 9.3 percent and the east received 10.0 percent of the 27 kips, as seen in Figure 17. But a comparison of the load sharing and deflection results after the exposure leads to some questions in the test.

It was unexpected that the east ply deflected 82 percent more at 27 kips after being exposed in the environmental chamber while the west ply experienced only a 7 percent increase in deflection at the same 27 kip load after exposure. The west ply underwent the similar deflections despite the fact that the average loads were transferred less to the west and center plies and more to east ply. In the second test, the load dropped from 2.5 to 2.3 kips in the west ply, while the load increased from 2.7 to 3.0 kips in the east ply. This relates to a 0.8 percent drop and a 1.1 percent increase in the total loads, respectively. A decrease in load should lead to a decrease in deflection in the west ply, but instead there was an increase in deflection. The increase in the load transferred to the east ply was similar to the decrease of load to the west ply. As a result, the 82 percent increase in deflection of the east ply is unexpected. A more intuitive result would be a similar deflection in the east ply to that of the west ply, with the east ply increasing deflection slightly and the west ply decreasing in deflection by nearly the same amount.

7. CONCLUSION AND RECOMMENDATIONS

The laboratory test specimen exhibited an increase in deformation after it was exposed to temperature and humidity cycles, but the percentage of the load transferred to an outer ply varied by a maximum of 1.6 percent.

A midspan deflection difference of over 100 percent between the east and west plies due to the maximum load was surprising. This seems to show that the east ply degraded significantly more than the west because of exposure, contrary to the assumption that they would behave similarly.

Despite more than double the deflection, the east ply carried more of the total load than the west, although the difference in the total load carried between the two was only 2.6 percent.

It is strongly recommended that more string potentiometers should be used in subsequent studies. It would have been helpful to have monitored the deflections at the midspan of the center ply and near the supports on the east and center plies. Measuring the moisture content of the plies before and after the cooling/dehumidifying cycle of the environmental chamber would have also been beneficial. The length of time of exposure in the environmental chamber was abbreviated because of prior equipment breakdowns. A longer term study may be warranted over a more extended period of time.

8. REFERENCES

1. Chow, P., Bernberg, E.J., Meimban, R.J., Bajwa, D.S., Oliva, D. Otter, D.E., and Uppal, A.S. (1997). Shear and Static Bending Stresses of Used Railroad Bridge Timber Structures. Association of American Railroads Report R-911.
2. Gutkowski, R.M., Doyle, K.R., and Balogh, J. (2002). Full-Scale Laboratory Testing of a Timber Trestle Railroad Bridge Chord (Phase 1). Mountain-Plains Consortium, Report 02-139.
3. Seigel, M. and Cerny, L. (1981). Study of Timber Trestles on Columbus and Greenville Railway, *AREA Bulletin 683*, vol. 82.
4. Uppal, A.S. (2001). Compendium of Recent Research on Railroad Timber Bridges and Their Components. Association of American Railroads. Report R-947, 97-106.
5. Uppal, U. Oliva-Maal, D. and Otter, D.E. (1999). Field Studies of Timber Railroad Bridges. Association of American Railroads, Transportation Technology Center, Inc. Report R-933.
6. Uppal, U. and Otter, D.E. (2002). Field Study of Strengthened Timber Railroad Bridge. Association of American Railroads, Transportation Technology Center, Inc. Report R-956.
7. Wipf, T.J., Wood, D., Otter, D., Rogers, P., and Uppal, A.S. (1997). Field Testing of Two Open Deck Timber Railroad Bridges. Association of American Railroads Report R-913.

9. APPENDIX

9.1 Appendix A

Date	Start Time	Stop Time	Min Temp (F)	Min Humidity (%)	Total Time (hr:min)	Total Time (hrs)
2-Jun	9:05 AM	2:55 PM			5:50	5.83
3-Jun	10:00 AM	3:30 PM	77.0	25	5:30	5.50
4-Jun	7:50 AM	4:15 PM	76.8	24	8:25	8.42
7-Jun	10:15 AM	6:30 PM	75.7	21	8:15	8.25
8-Jun	10:15 AM	2:45 PM	78.3	25	4:30	4.50
9-Jun	10:00 AM	2:50 PM	77.2	37	4:50	4.83
10-Jun	10:20 AM	3:30 PM	72.7	44	5:10	5.17
11-Jun	8:00 AM	3:00 PM	70.5	21	7:00	7.00
14-Jun	10:00 AM	4:00 PM	86.0	60	6:00	6.00
			71.8	39		
					total hours	55.50

9.2 Appendix B

Date	Start Time	Stop Time	Min Temp (F)	Min Humidity (%)	Total Time (hr:min)	Total Time (hrs)
16-Jun	10:30 AM	2:45 PM			4:15	4.25
17-Jun	10:35 AM	4:13 PM	68.2	48	5:38	5.63
18-Jun	9:45 AM	5:00 PM	66.4	51	7:15	7.25
21-Jun	10:15 AM	3:40 PM	66.6	47	5:25	5.42
22-Jun	9:50 AM	3:00 PM	65.8	45	5:10	5.17
23-Jun	11:00 AM	3:55 PM	65.8	38	4:55	4.92
24-Jun	9:50 AM	3:02 PM	70.2	38	5:12	5.20
25-Jun	9:38 AM	12:46 PM	69.4	45	3:08	3.13
28-Jun	9:30 AM	3:15 PM	68.0	47	5:45	5.75
29-Jun	10:21 AM	3:15 PM	68.7	51	4:54	4.90
30-Jun	11:53 AM	1:26 PM	70.7	46	1:33	1.55
1-Jul	10:06 AM	4:27 PM	69.3	47	6:21	6.35
2-Jul	10:48 AM	1:53 PM	70.7	52	3:05	3.08
6-Jul	10:15 AM	3:11 PM	69.1	44	4:56	4.93
7-Jul	10:45 AM	2:40 PM	70.9	41	3:55	3.92
8-Jul	9:55 AM	11:59 PM	74.3	32	14:04	14.07
9-Jul	12:00 AM	10:00 AM			10:00	10.00
12-Jul	10:18 AM	2:20 PM	73.2	24	4:02	4.03
13-Jul	10:15 AM	2:15 PM	77.4	31	4:00	4.00
14-Jul	10:22 AM	4:30 PM	78.1	32	6:08	6.13
15-Jul	10:57 AM	1:44 PM	77.5	41	2:47	2.78
16-Jul	10:00 AM	2:26 PM	76.5	40	4:26	4.43
19-Jul	10:13 AM	12:15 PM	73.6	32	2:02	2.03
20-Jul	10:12 AM	1:40 PM	75.2	42	3:28	3.47
22-Jul	8:30 AM	11:15 AM	75.6	30	2:45	2.75
23-Jul	10:15 AM	12:45 PM	70.0	48	2:30	2.50
26-Jul	10:15 AM	12:00 PM	66.4	53	1:45	1.75
27-Jul	10:15 AM	3:04 PM	66.4	47	4:49	4.82
			69.3	49		
					total hours	134.22

9.3 Appendix C

Test 1		
	E= - 0.1700 W= - 0.1475	
C	27.0	27.0
E	2.7	X
W	X	2.5
delta P	24.3	24.5
E/W %	10.0%	9.3%
	E= - 0.1600 W= - 0.1425	
C	25.0	25.0
E	2.5	X
W	X	2.4
delta P	22.5	22.6
E/W %	10.0%	9.6%
	E= - 0.1375 W= - 0.1250	
C	20.0	20.0
E	2.3	X
W	X	2.3
delta P	17.7	17.7
E/W %	11.5%	11.5%

Test 2		
	E= - 0.3100 W= - 0.1575	
C	27.0	27.0
E	3.0	X
W	X	2.3
delta P	24.0	24.7
E/W %	11.1%	8.5%
	E= - 0.2950 W= - 0.1500	
C	25.0	25.0
E	2.7	X
W	X	2.1
delta P	22.3	22.9
E/W %	10.8%	8.4%
	E= - 0.2675 W= - 0.1225	
C	20.0	20.0
E	2.3	X
W	X	1.7
delta P	17.7	18.3
E/W %	11.5%	8.5%