

	STATE	PROJECT NO.	SECTION NO.	SHEET NO.
	ND	PROJECT NUMBER	SEC	PAGE

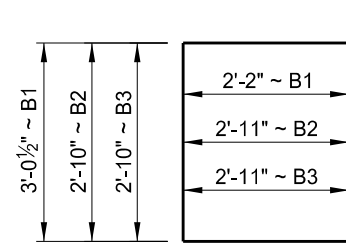

B1, B2 & B3

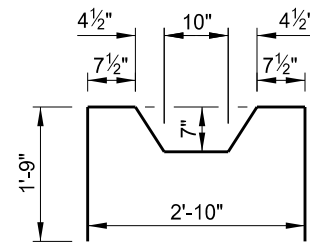

B4

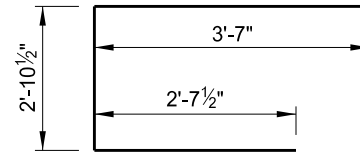

B5

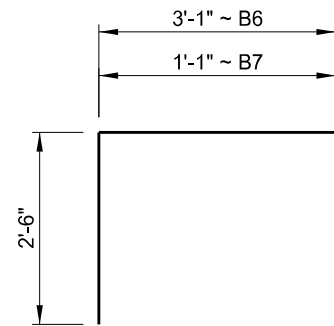

B6 & B7

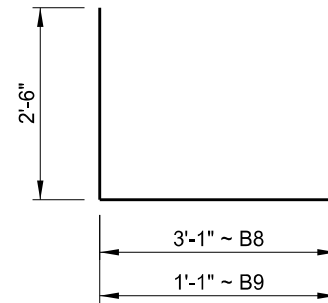

B8 & B9

BENT BAR DETAILS

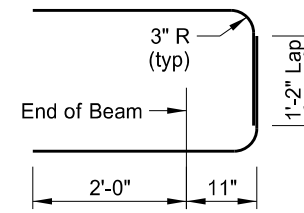

T1

NOTES:

All bar dimensions are out-to-out.

Unless noted otherwise, bend bars to the bend diameter (D) listed below.

- #3 Bar: D = 1 1/2"
- #4 Bar: D = 2"
- #5 Bar: D = 2 1/2"

NOTES:

Provide lifting loops or handling hooks as required by the Contractor. Additional inserts, brackets, and hardware may be incorporated into the finished beam for the convenience of the Contractor. Use galvanized, epoxy-coated, stainless steel, or non-metallic material for all inserts, brackets, and hardware if less than 1 inch of concrete cover will be provided in the finished structure.

The required Detensioning Strength indicates the minimum required concrete strength at the time of prestress transfer. The required Acceptance Strength indicates the minimum required concrete strength prior to transporting and erecting the beams.

Y Distances shown in the table are measured from the bottom of the beam to the center of gravity of the strand group listed.

Minor changes to the shape of the beam and to the reinforcing steel may be made to accommodate the forms of various Contractors and their construction methods with the approval of the Engineer.

NOTE:

See Dwg 0-000.000-0 for location of Section D-D.

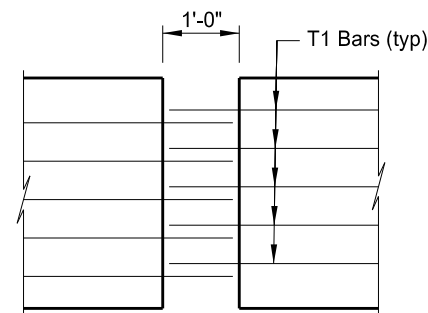

BEAM END PLAN AT PIER

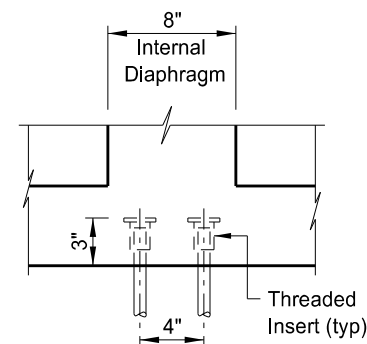

(OUTER BEAMS ONLY)
DIAPHRAGM BAR INSERT
D-D

This drawing is preliminary and not for construction or implementation purposes.

LOCATION	
PRE-TENSIONED 39" x 36" PRESTRESSED SPREAD BOX BEAM	
DRAWING NO.	BN-page