

STATE	PROJECT NO.	SECTION NO.	SHEET NO.
ND	SS-6-032(075)230	170	5

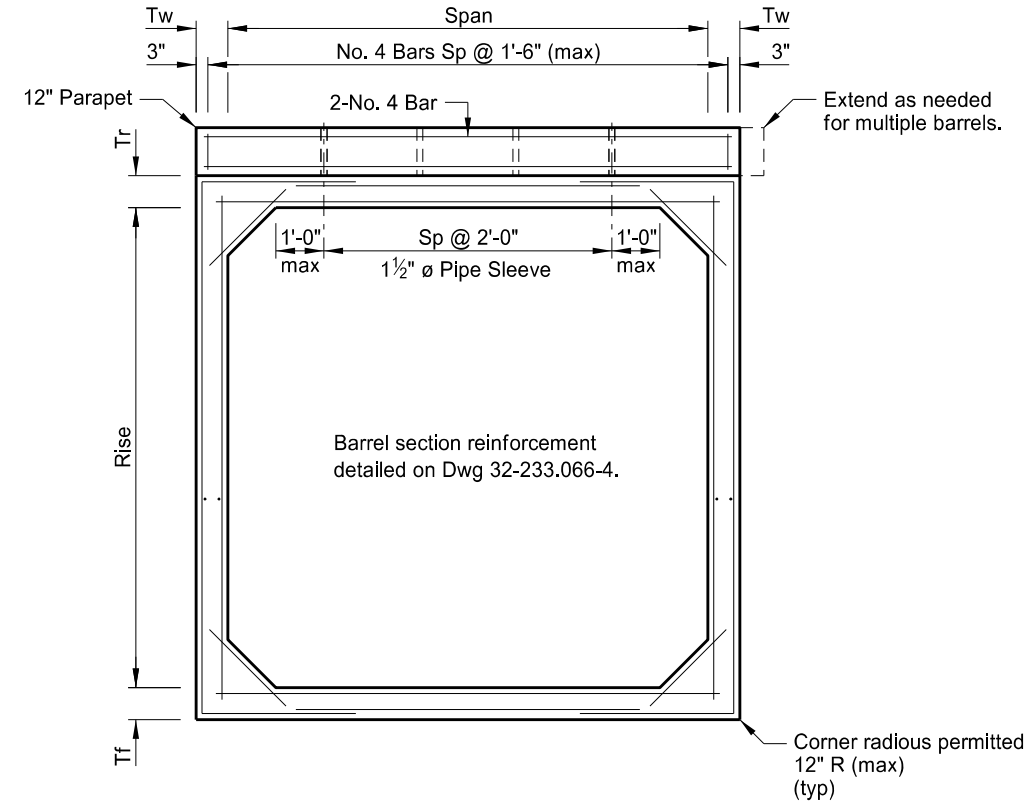

A-A

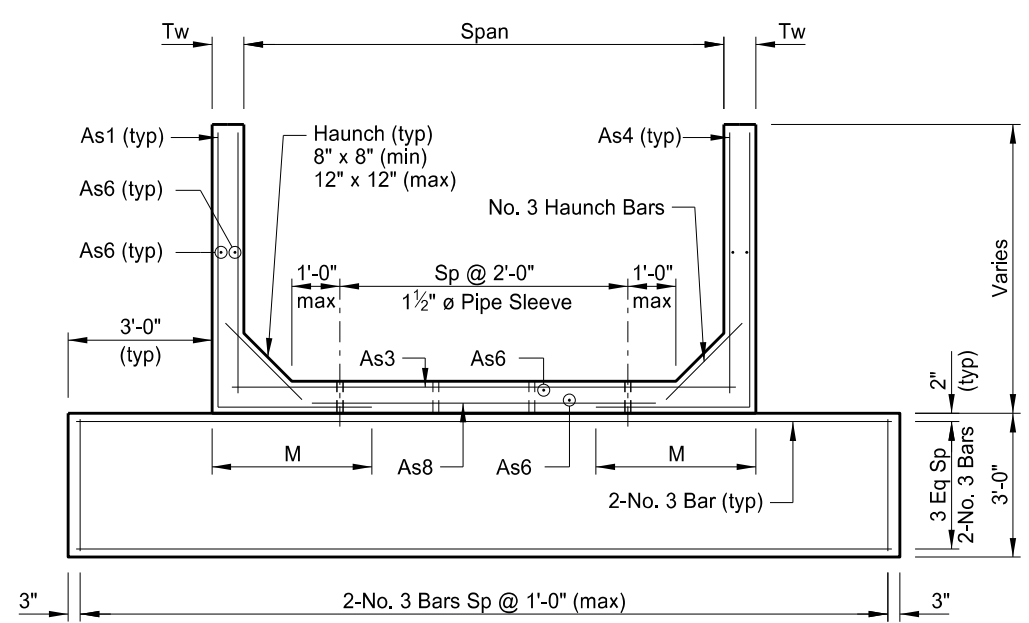

B-B

END SECTION INFORMATION TABLE																
STRENGTH f _c (KSI)	DIMENSIONS						WELDED WIRE REINFORCEMENT									
	SPAN	RISE	L	Y	T _f	T _w	As1		As3		As4		As6		As8	
							AREA (IN ² / FT)	M	AREA (IN ² / FT)	LENGTH	AREA (IN ² / FT)	AREA (IN ² / FT)	AREA (IN ² / FT)	LENGTH		
5.00	14'-0"	7'-0"	12'-0"	1'-9"	9"	8"	0.255	3'-2"	0.240	14'-6"	0.225	0.060	0.225	12'-0"		

NOTES:

Provide 1 1/2" minimum concrete cover on all reinforcement.
 Barrel section to end section joint not shown. Location of joint to be determined by the manufacturer. Tie joint as shown for barrel section and end section joints.

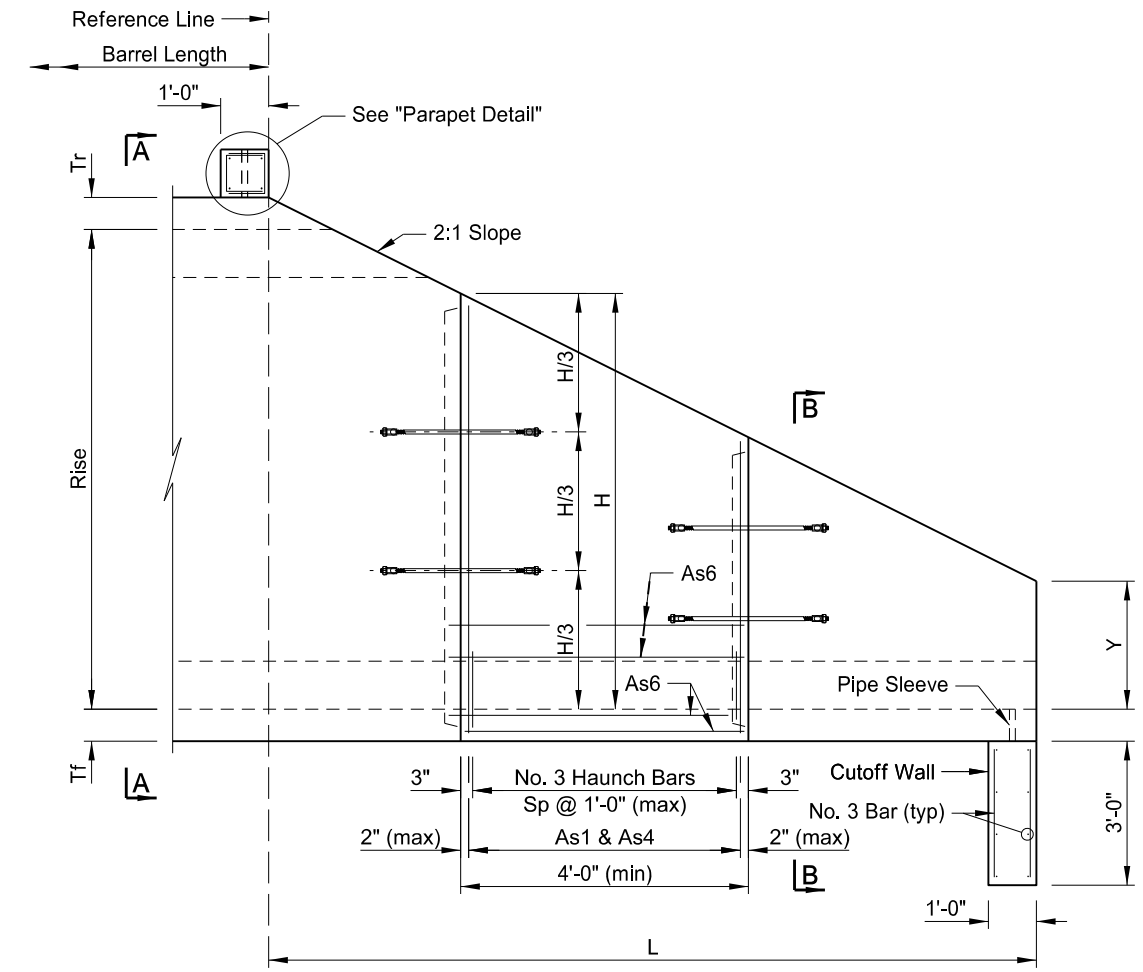

END SECTION ELEVATION

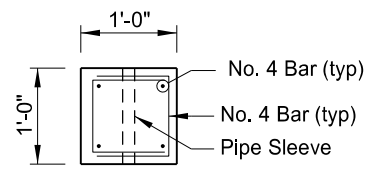

PARAPET DETAIL

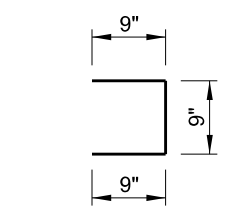

NO. 4 BAR BENT BAR DETAILS

This drawing is preliminary and not for construction or implementation purposes.

CREEK	
END SECTION & REINFORCING STEEL TABLE	
DRAWING NO.	32-234.484-5