

Square Tube Brace For Wood Posts	
Quantity	Description
1	1/4" x 2" Long Hex Head Bolt
4	5/16" x 3" Long Hex Head Lag Bolt
2	FL 1/8" x 2" x 6"
1	Square Tube - 1 1/2" x 1 1/2" x 72" Long (16 GA)
1	Square Tube - 1 1/4" x 1 1/4" x 48" Long (16 GA)

SQUARE TUBE BRACE

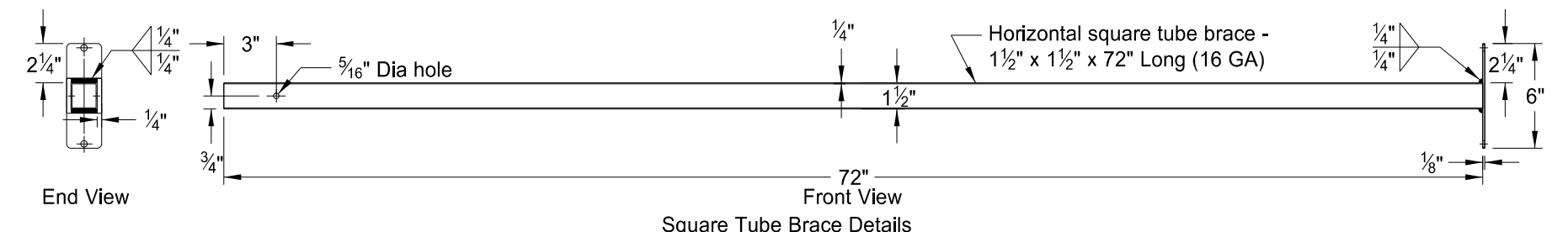

ROUND PIPE BRACE

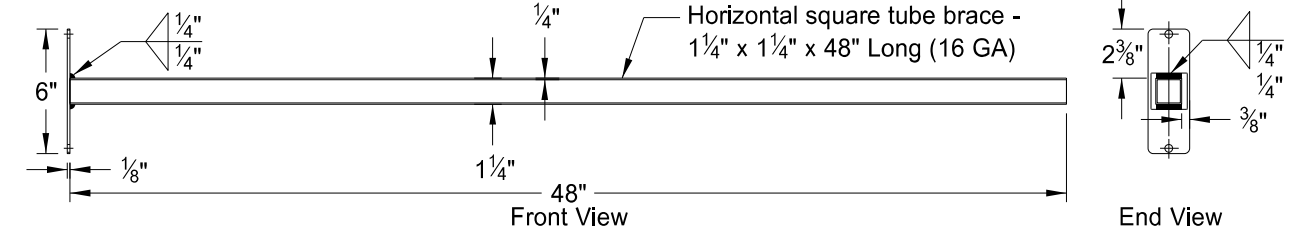
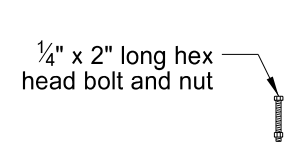
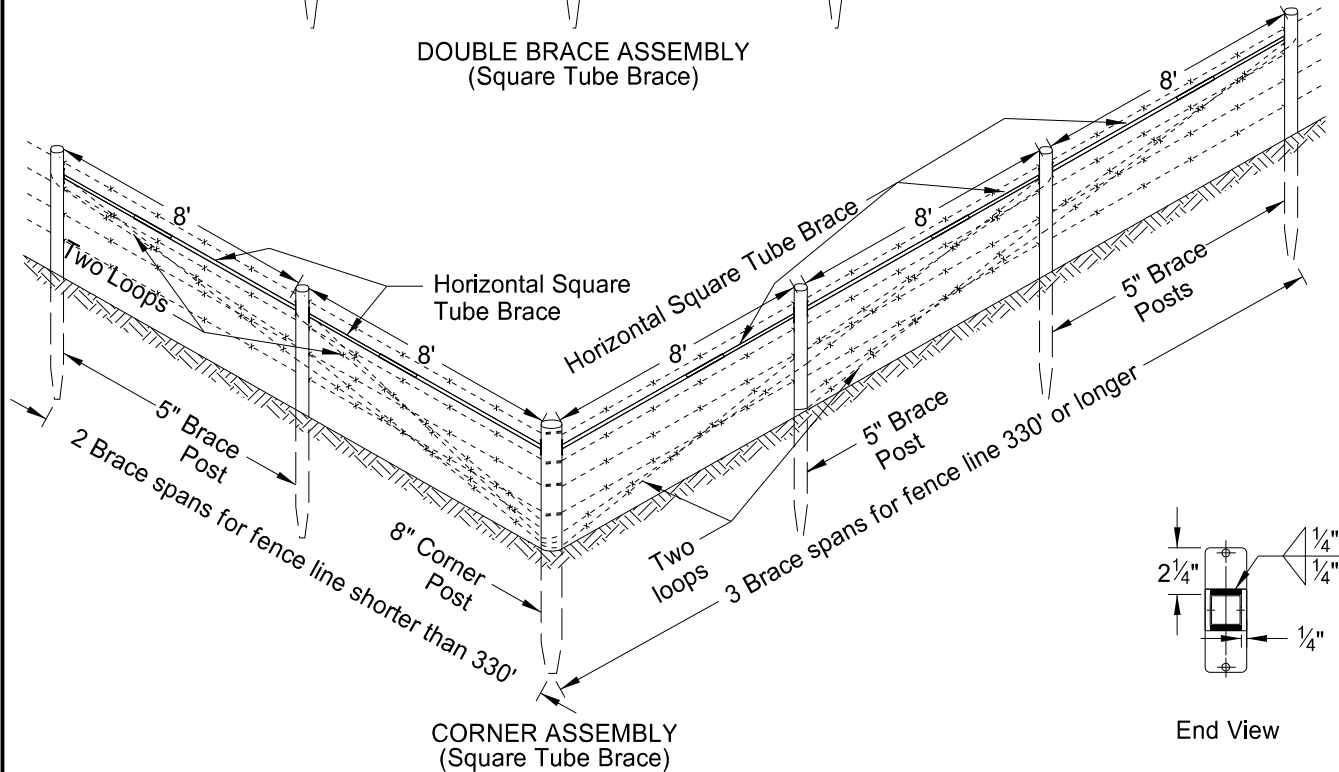
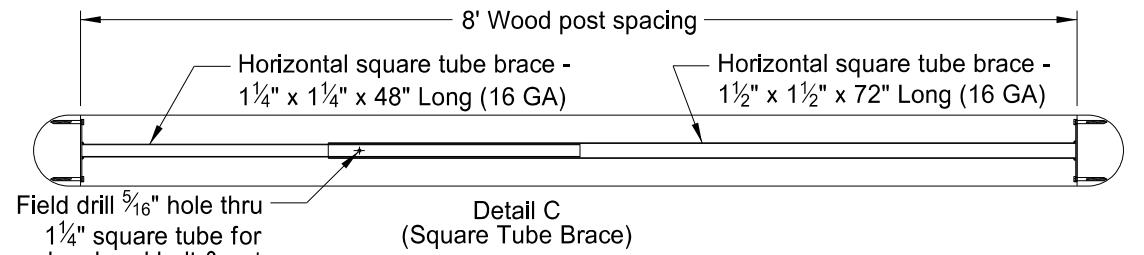
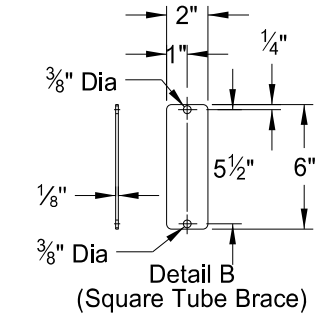
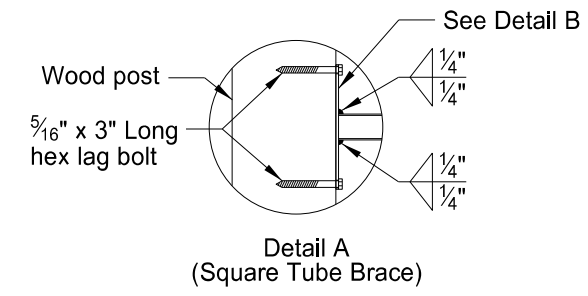
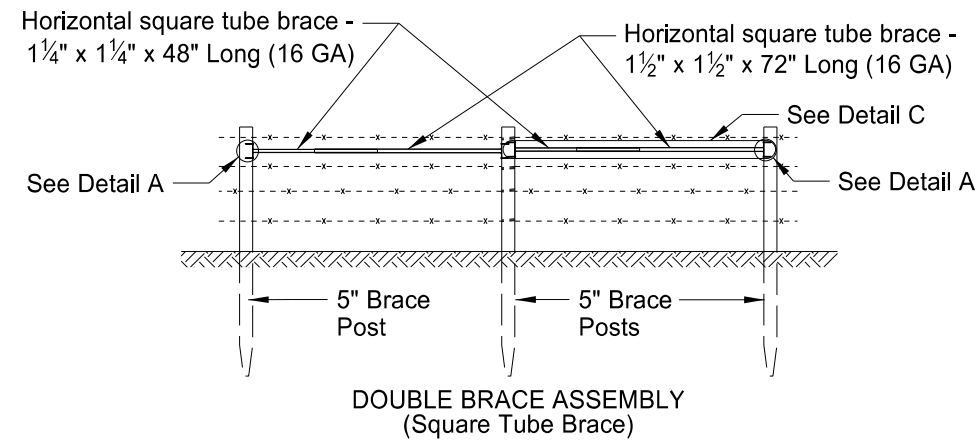
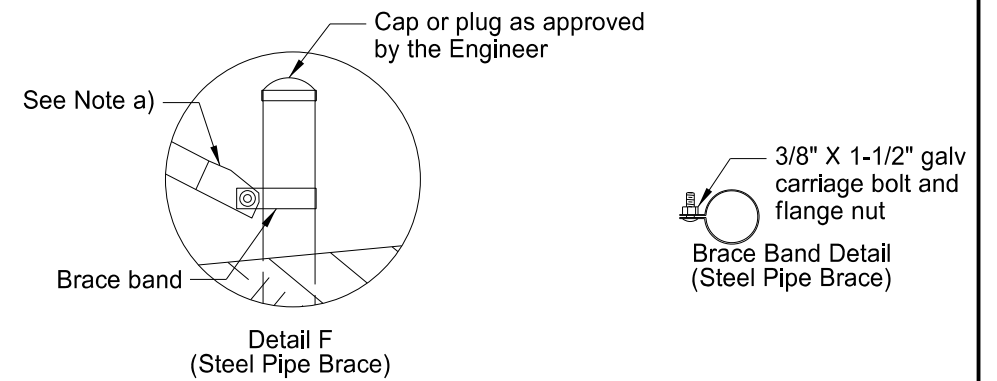
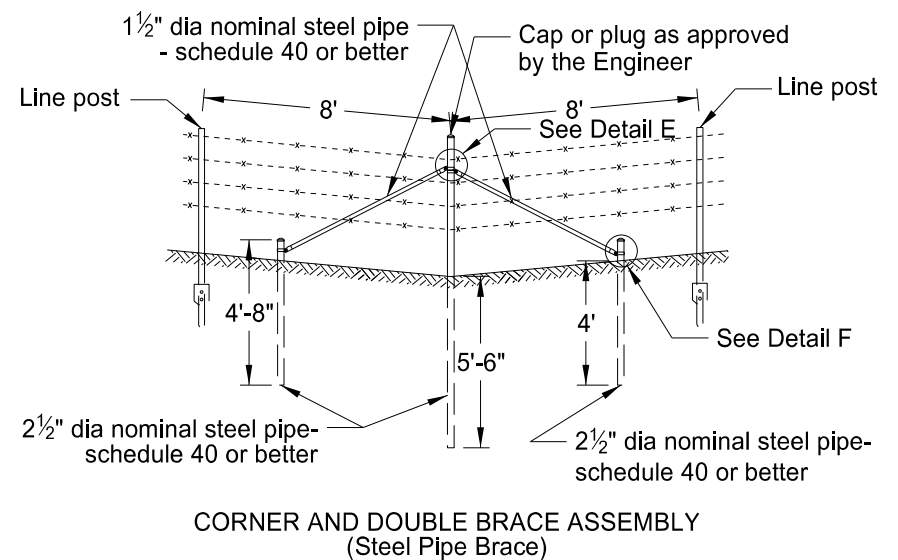
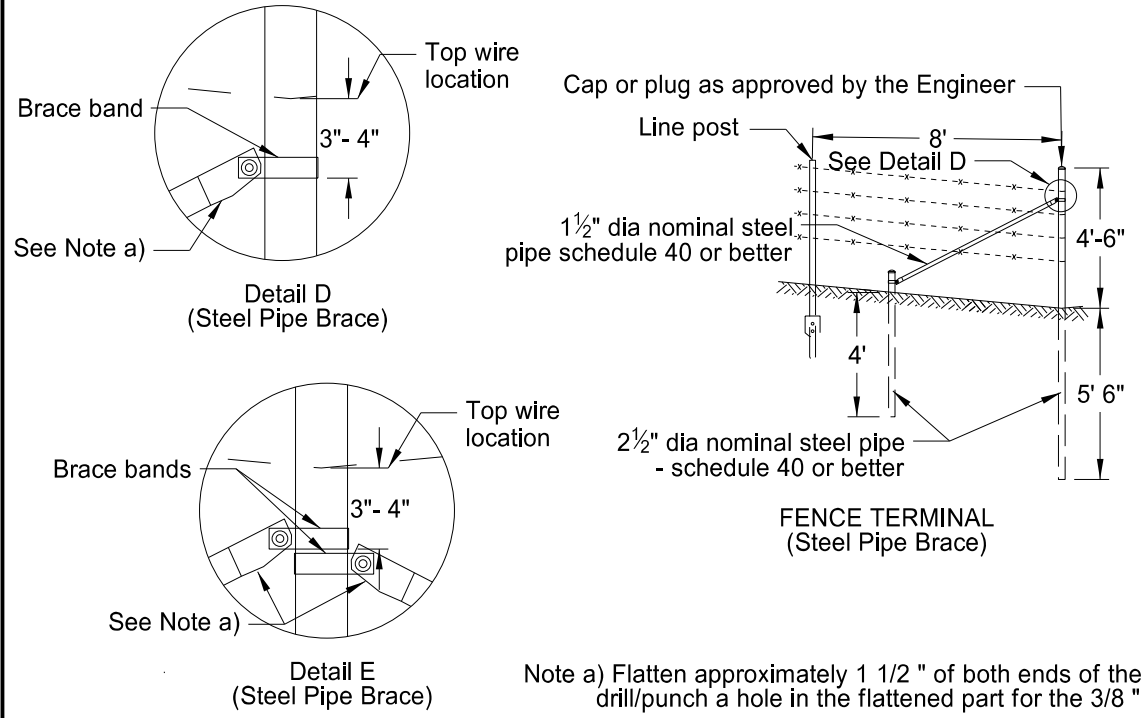

Corner and Double Brace Assemblies
Square Tube Brace and Round Pipe Brace Alternates

Project Description

Project Location

This document is preliminary and not for construction or implementation purposes.