

	STATE	PROJECT NO.	SECTION NO.	SHEET NO.
	ND	PROJECT NUMBER	20	PAGE

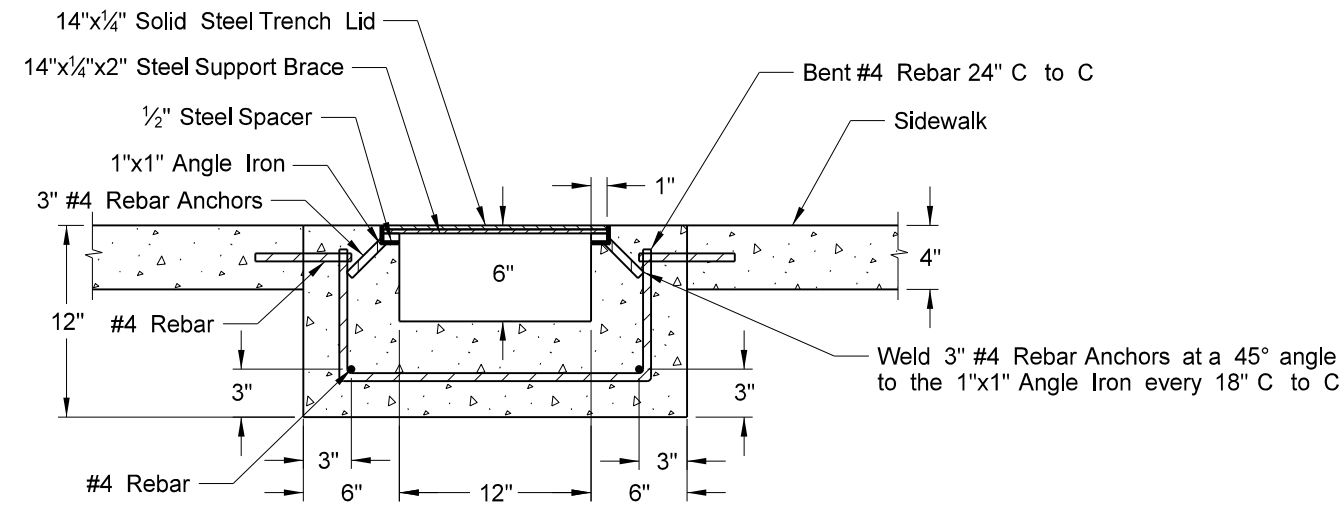

Sidewalk Trench Drain Detail

Note: Weld 1/4"x2" Steel Support Braces and 1/2" Steel Spacers to the 1"x1" Angle Iron

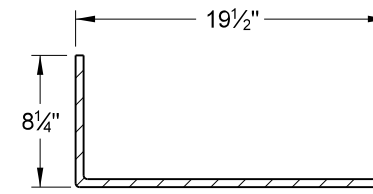

Bent Rebar Detail

NOTES

Two locations (See Plan & Profile Sheets)

Approximate lengths:  
 1 trench drain approximately 6' length  
 1 trench drain approximately 10' length

\*Verify exact length required in the field prior to fabrication.

\*Sidewalk Trench Drain as shown, or approved equal

NOTE: Provide a solid steel trench lid with a slip resistant surface.

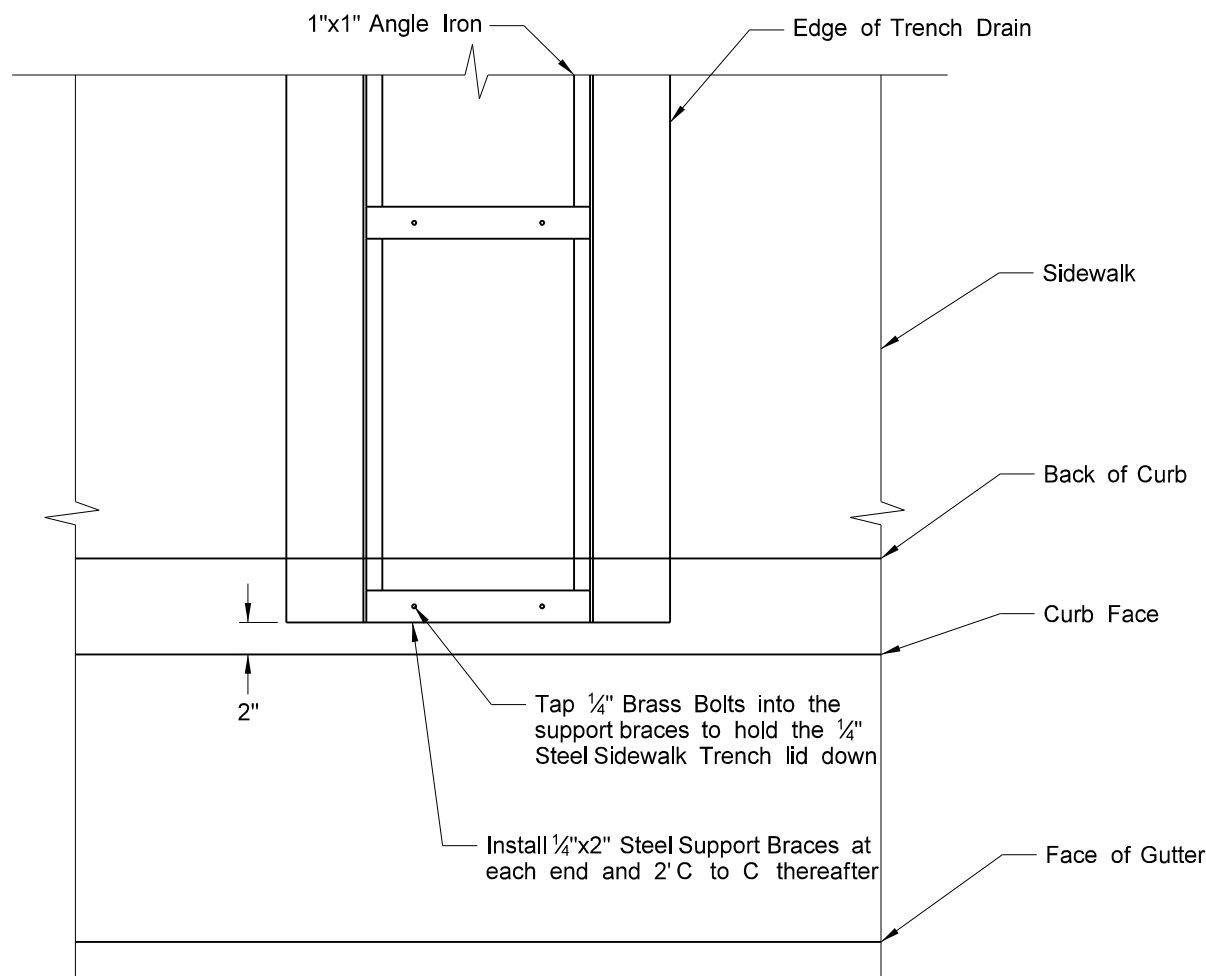

Steel Support Brace Detail

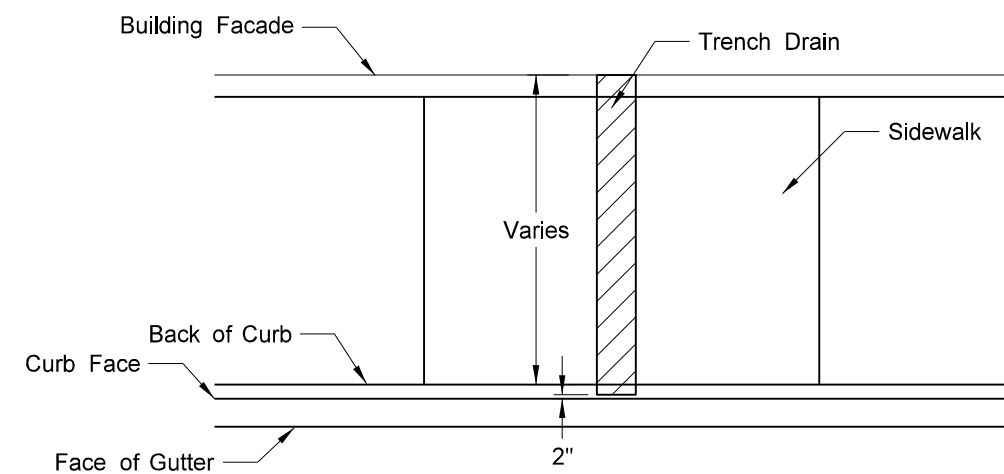

Trench Drain Layout

Note: Begin Trench Drains at property line or building facade and extend to 2" from the face of the curb.

Trench Drain Installation (or approved equal)	This document is preliminary and not for construction or implementation purposes.
Project Description	
Project Location	