

TRANSVERSE JOINTS

** Joint Spacing to match existing (Varies from 14' to 18')

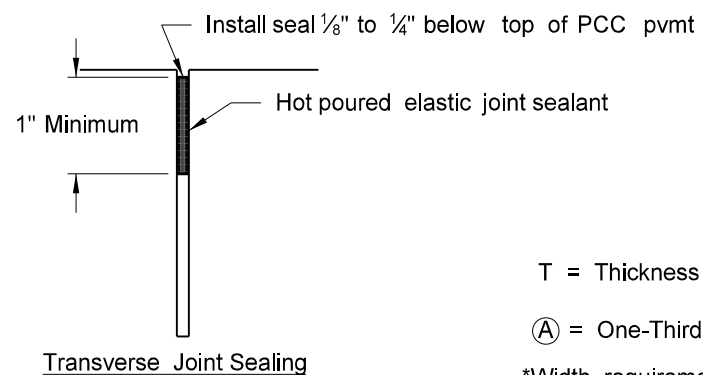
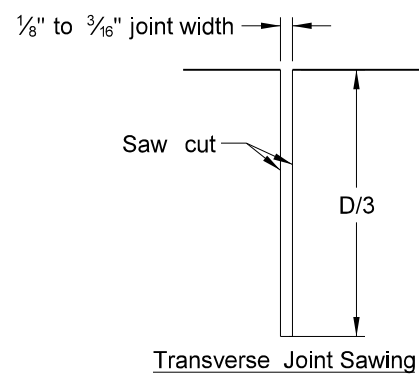
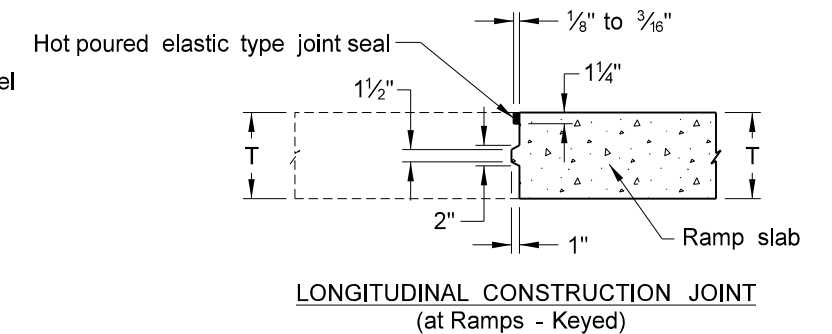
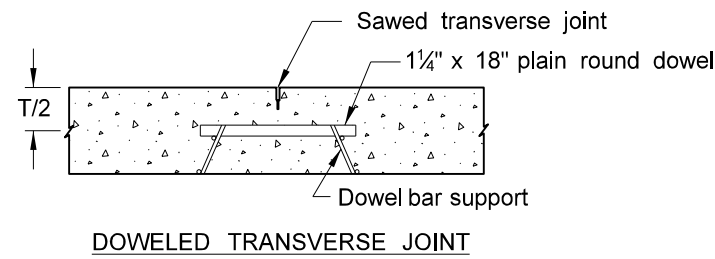
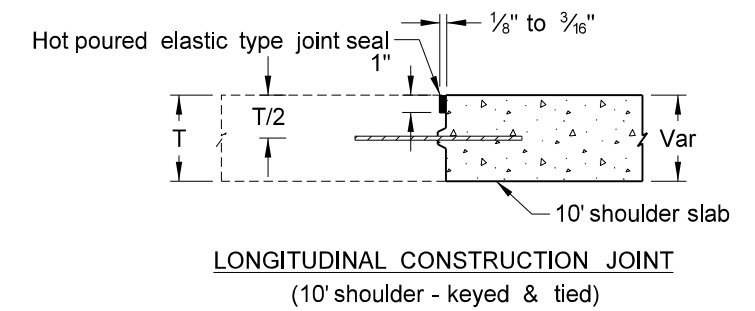
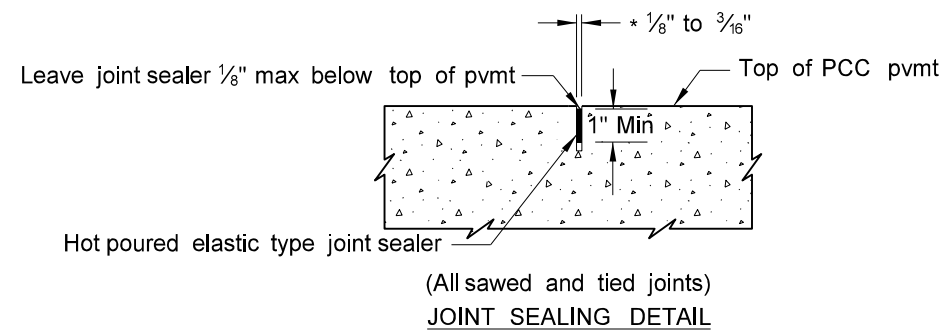
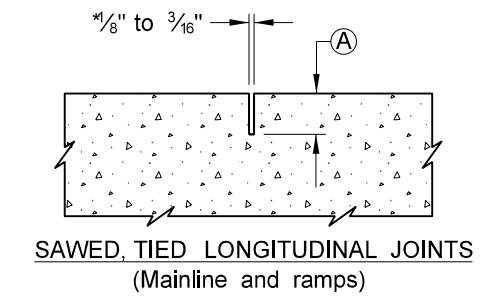
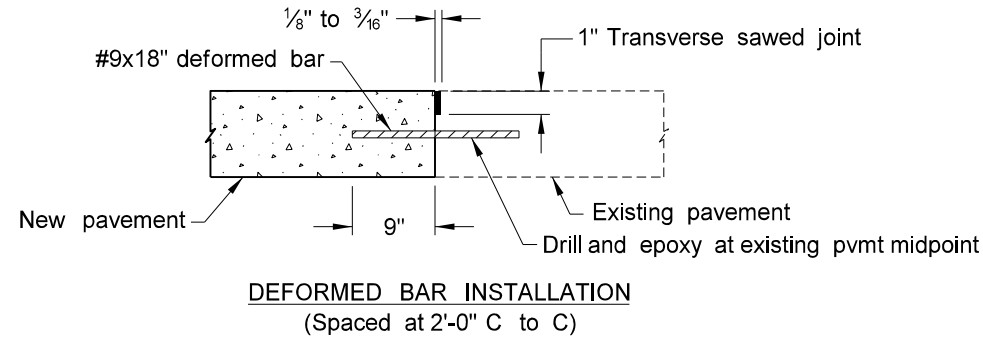

T = Thickness of PCC Pvmt

Ⓐ = One-Third thickness of PCC Pavement

*Width requirement for top 1" only, bottom portion of sawcut may be narrower.

Joint Details for Repairs 1 Panel or More in Length	This document is preliminary and not for construction or implementation purposes.
Project Description	
Project Location	