

Dowel Bar Retrofit Spacing

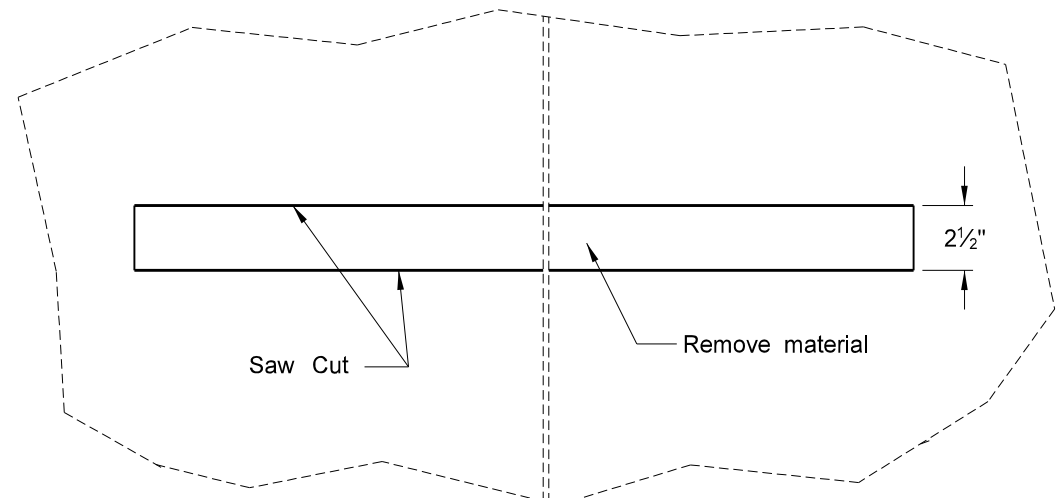

Plan View Dowel Bar Retrofit Slot Material Removal

Note: Saw and Seal the 12' driving lane where the dowel bar retrofit is placed according to the Dowel Bar Retrofit Silicone Joint Detail. Include all costs to saw and seal the dowel bar retrofit joints in the unit price bid for "Transverse PCC Joint Cleaning & Sealing."

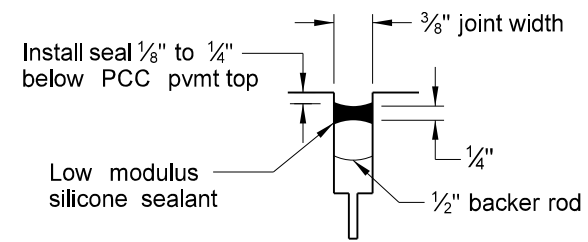

Transverse Joint Seal

Dowel Bar Retrofit Silicone Joint Detail

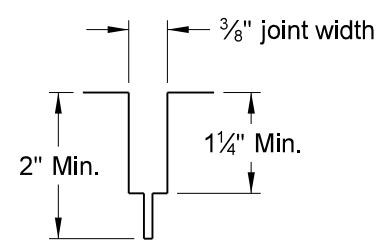

Transverse Joint Sawing

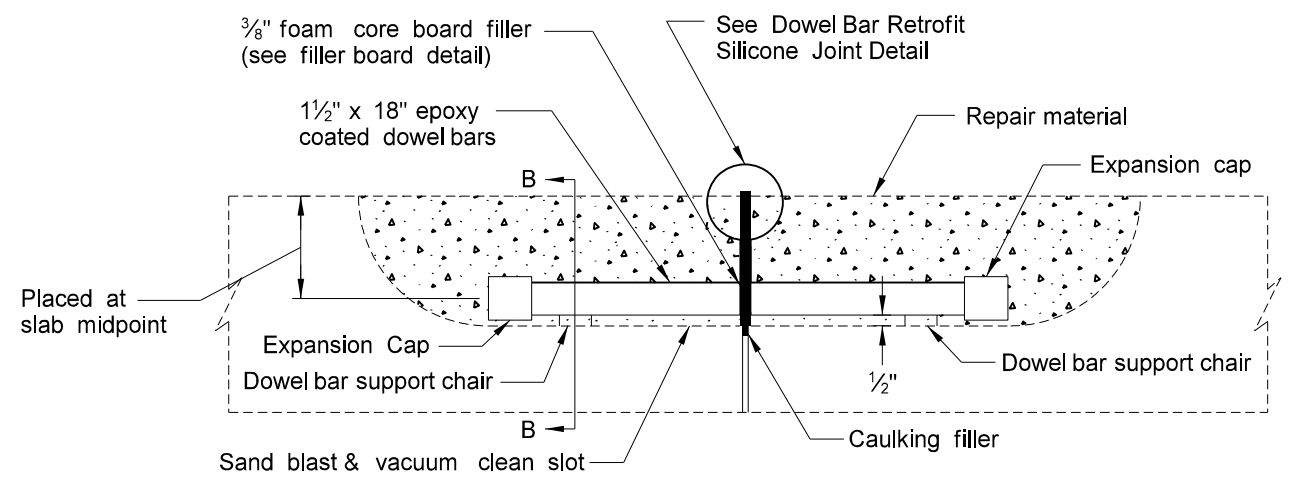

Section A-A

Dowel Bar Installation Detail

NOTE: Place repair material above the existing PCC pavement (a maximum of 1/4 inch.)

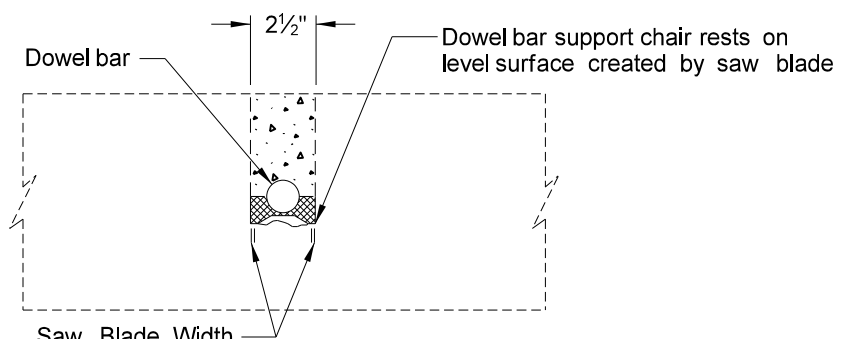

Section B-B

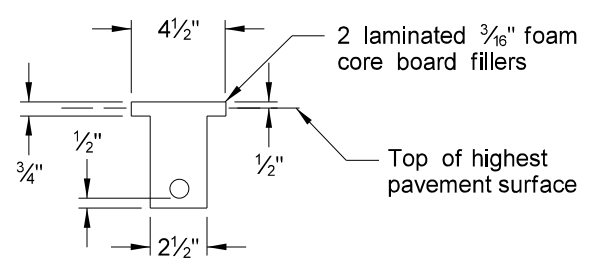

Filler Board Detail

Dowel Bar Retrofit Installation Detail	
Project Description	
Project Location	

This document is preliminary and not for construction or implementation purposes.